

Mecalac

MWR
SERIES



MWR
SERIES **Mecalac**



7 MWR

9 MWR

11 MWR



MWR SERIES

HUMAN ENGINE, HUMAN MACHINE

“For the past 60 years, innovation, accuracy and the search for performance have been the leading keywords of our company’s vision. At Mecalac, we imagine the machines designed for the construction sites of the 21st century. Since every job has its own characteristics and restrictions, since each country has its own culture, we build machines that respond perfectly to today’s challenges. Our machines are created by men, for men! We are proud to be human innovators who improve and push back the limits of our clients’ objectives.”

Henri Marchetta, Chairman
Groupe Mecalac S.A.



MWR 7.9.11

THE BEST OF 2 WORLDS

**LOWERING
THE CENTER
OF GRAVITY,
SIMPLY
REVOLUTIONARY!**



The fusion of the advantages of wheeled and crawler excavators brought about a unique Mecalac solution, conjugating mobility, versatility, stability, accessibility, driving user friendliness, lifting power and profitability. This is MWR series.





WATCH THE VIDEO

**MECALAC INNOVATES
AND OFFERS YOU TO
WATCH MWR VIDEOS.**

It's easy, all you need to do is scan the QR codes present on the pages of the brochure with your smartphone in order to access the video content.

If you don't have a scanning app, you can download a QR code scanner from the App Store or Google Play.





7.9.11 MWR

FROM GENESIS TO SOLUTION

DESIGN: A STRONG AND STRATEGIC COMPONENT OF THE MECALAC IDENTITY

“Our strength? Offering each client the most efficient solution. A deep analysis of users’ work process allows us to provide the right industrial and versatile answer to their requests. This approach allows to offer better fitted machines based on the real needs of the jobsite. At Mecalac, design has always been part of our creation process. It is a strong and strategic component of our brand identity and products and is not limited to mere aesthetics. Our design is functional and secure. It blends ergonomics with smooth flowing lines”.

Patrick Brehmer,
Head of Marketing,
Product Management & Design

AN EXCLUSIVE CONCEPT, A UNIQUE SOLUTION

By lowering the center of gravity of the new MWR relative to its competitors, Mecalac revolutionizes by 100% the world of wheeled excavators.

Consequences on all 'levels': from stability to accessibility, by way of security and 'all terrain' mobility, the machine gains in balance and in force without dropping any of its initial qualities.

More than a machine, the MWR is the achievement of a new concept and the result of a combined expertise of Mecalac for both wheeled and crawler excavators.

Its design has been developed to answer very demanding and complex specifications which Mecalac managed to implement in one single and unique machine.

The result: a machine with XS proportions and with XL lifting power, versatile and ultra-stable.

Moreover, the 9MWR benefits from the latest interior and exterior patented Mecalac technologies (articulated boom with offset, cylinder coupling, Connect quick coupler, central command selector, 'speed control' function).

AWARD 2016

Mecalac wins the Prize for Design of the 2016 Innovation AWARDS at the world exhibition BAUMA for the new concept of excavators on tyres: MWR.

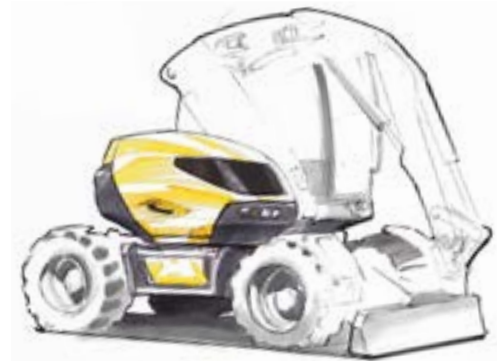



	WHEELED EXCAVATORS	CRAWLER EXCAVATORS	MWR
Mobility	•		•
Versatility	•		•
Autonomy	•		•
Driving user-friendliness		•	•
Ability for all types of terrain		•	•
Security		•	•
Accessibility		•	•
Stability		•	•



MWR 7.9.11

USER FRIENDLY

**Optimize security for
the operator as for the
workers' team of both
urban and suburban
construction sites:**

- maintenance feet on the ground
- oscillation locking by the brake pedal and the joystick
- reduced access height
- excellent compactness
- optional integrated and automated cameras
- excellent visibility





1 BUTTON
3 MODES





WATCH THE VIDEO



USER-FRIENDLY

DRIVING USER-FRIENDLINESS

**PARKING, WORK OR ROAD
MODE, IN ONE SINGLE
SWITCH.**

Thanks to the unique central selector, the driver can switch into road or parking mode in a single movement, thus sparing 7 to 10 manipulations. With this unique global exclusivity, everything can be done instantly by selecting the desired configuration.

With this unique, worldwide exclusive, everything can be done instantly by selecting the desired configuration. This guarantees faultless and ultra-safe driving on construction sites, leaving the driver free to calmly focus on the tasks at hand and take full control of the machine.





USER-FRIENDLY

CONNECT 'ATTACHED' TO VERSATILITY

**IN ORDER TO MAKE ITS MACHINES
EVER SAFER AND MORE VERSATILE,
MECALAC INTRODUCES CONNECT,
ITS PATENTED QUICK COUPLER,
NOTABLE FOR ITS LIGHTNESS,
INTEGRATION, USER-
FRIENDLINESS, REVERSABILITY
AND ITS PERFECT SAFETY.**

Controlled from the cab, there is zero risk of it detaching from the tool either while it is being connected or while in operation. It is equipped with a detection system that alerts the driver if the tool is improperly secured (with visual and audible signals). Not only that, but it is also reversible and has an automatic play compensation function, making the CONNECT quick coupler the ultimate connection between tool and machine!





WATCH THE VIDEO







USER-FRIENDLY

THE QUEST FOR SIMPLICITY: DRIVING OUR RESEARCH

THE MWR REPRESENTS A NEW WAY TO INTERACT WITH CONSTRUCTION VEHICLES, THANKS TO ITS COMPLETELY REDESIGNED INTERNAL AND EXTERNAL ERGONOMICS AND UNIQUE INTERFACE BETWEEN HUMAN-MACHINE THAT COMBINES ACCESSIBILITY AND SAFETY.

Each and every driver action is simplified, affording greater protection of everybody on the worksite. When it comes to innovation, 'less is more' is definitely one of the keys to Mecalac's success.





WATCH THE VIDEO

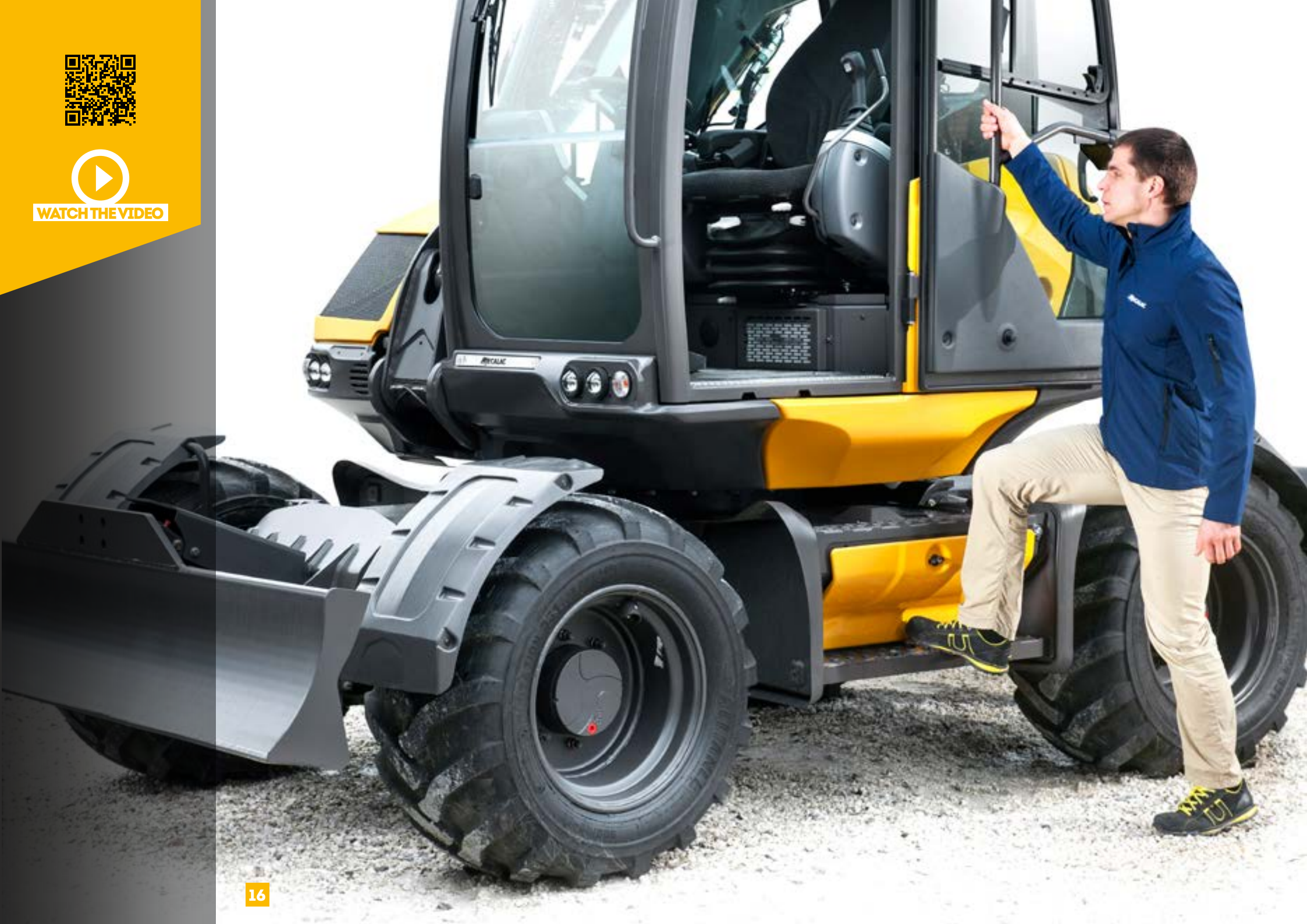



USER-FRIENDLY

CLIMB UP AND DOWN EASILY

**THANKS TO THE LOWERED
CENTRE OF GRAVITY OF
THE MACHINE, THE CABIN
IS PERFECTLY ACCESSIBLE
TO THE DRIVER, WITHOUT
MAKING TOO MUCH EFFORT
OR TAKING ANY RISKS.**

The cab is 20% lower compared to rival products on the market so now entering and exiting the vehicle requires much less effort, and is further eased by the addition of a step that has been perfectly incorporated into the machine's design. One small step for man; one giant leap for worksite safety.







WATCH THE VIDEO



USER-FRIENDLY

FILL UP YOUR TANK EFFORTLESSLY

**THE TANK IS EXTREMELY
ACCESSIBLE AS IT IS LOCATED
ON THE UNDERCARRIAGE
AT A REACHABLE HEIGHT.**

Besides helping lower the centre of gravity, the lower-down position of the tank and its increased capacity also mean that the driver or fleet manager no longer has to carry out any operations at height, nor is there anything in the way when driving the vehicle. With the majority of other excavators still mounting the fuel tank in the upper carriage, filling up an MWR is as simple as it is safe. Because daily upkeep should always be risk-free.





MWR 7.9.11

OPTIMAL PERFORMANCE

MWR machines are equipped with numerous technical characteristics for optimal construction site management on all types of terrain.

- naturally balanced
- all terrain capacity
- manoeuvrability
- agility
- compactness
- lifting power



MECALAC

MECALAC



PERFORMANCE

NATURALLY BALANCED

THE NEW MWRS BENEFIT FROM 360° ISO STABILITY: THIS MEANS THE MACHINE'S STABILITY REMAINS THE SAME REGARDLESS OF THE ROTATION ANGLE OF THE UPPER CARRIAGE.

Lift, place, move, unload... all without moving. The new MWRS transform worksite logistics thanks to their incredible stability in any position and on any terrain. Whatever the conditions, they stay balanced both when travelling in transfer operations between sites as well as during work phases. This gives them 360° lifting performance - an extraordinary feat.





PERFORMANCE

GROUND CLEARANCE

THE LOWERED CENTER OF GRAVITY HAS ABSOLUTELY NO INCIDENCE ON THE GROUND CLEARANCE HEIGHT, WHICH IS AN EXCLUSIVE 'MADE IN MECALAC' PARADOX.

In order to guarantee the machine's mobility in spite of ground's unevenness, the machine keeps enough height to avoid rubbing and risks of tearing out the undercarriage.





PERFORMANCE

MANŒUVRABILITY & COMPACTNESS

The new MWRs can be equipped with 4 steering wheels thus allowing you to do a U-turn practically on the spot and effectively overcome all obstacles. The aim: ensuring a maximum mobility in narrow spaces.

**2,5 TIMES
MORE COMPACT
THAN A CLASSIC
EXCAVATOR**



AGILITY

Efficiency of movement

When the leeway is limited, the MWRs are a powerful ally. Their perfectly integrated and light offset and their 3-part arm allow them to work outside the pattern of the machine.

MOBILITY

Best manoeuvrability

The 3 direction modes enable the MWR to get out of any situation.

COMPACTNESS AT WORK

in the service of security

With their XS dimensions, their 360° rotation and their exceptional angular displacement of the boom, the MWRs only require one way in an urban area to carry out their missions, thus preserving the security of pedestrians and of car drivers.

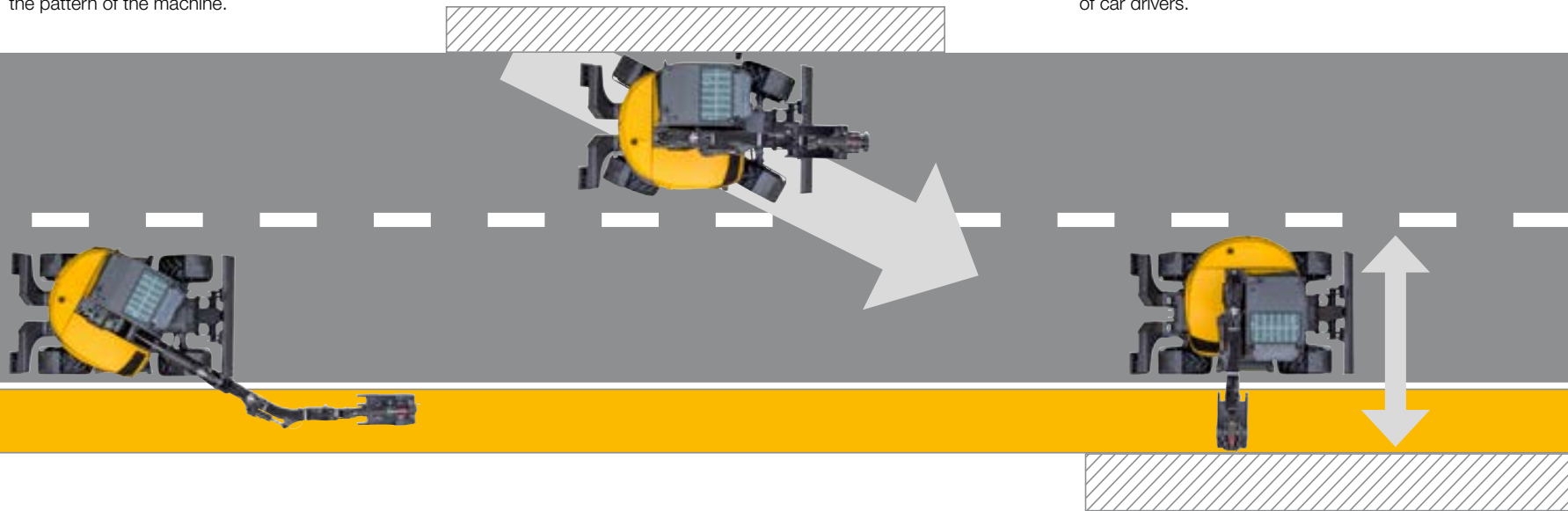

MAXIMUM COMPACTNESS

for minimum bulk

This useful compactness frees 100% performances and 100% functions, therefore reducing the impact of urban construction sites on the environment.

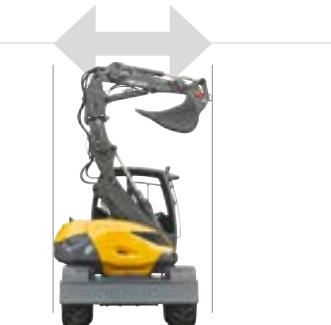



PERFORMANCE

LIFTING POWER & AMPLITUDE



AN UNRIVALLED COMPACTNESS/LIFTING CAPACITY RATIO:

The unique architecture of the new MWRs makes these powerful and precise handling machines capable of lifting up to 3 tons to 3 m and 360°!



360°



AMPLITUDE

Equipped with a loader bucket or with pallet forks, the new MWRs allow for an unusual range of amplitude whether this is positive for loading a truck or negative for offloading pallets.

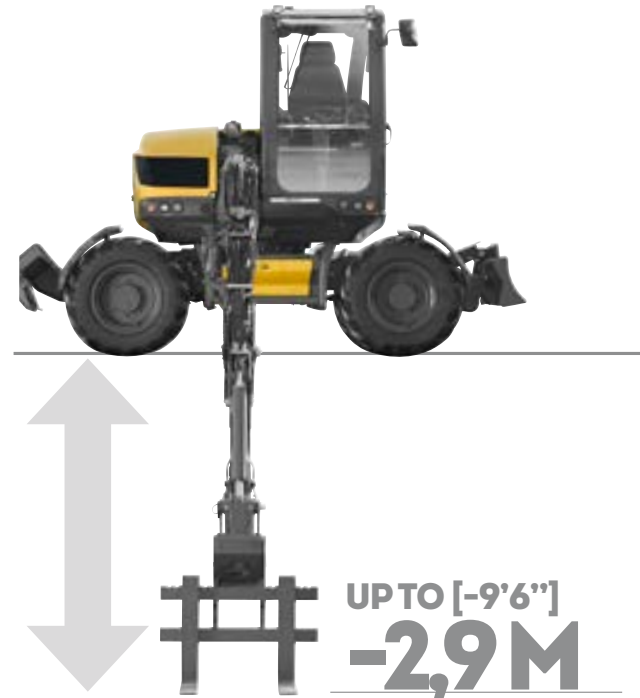

WATCH THE VIDEO





PERFORMANCE

FROM VERSATILITY TO AUTONOMY

EXPERTISE IS BORN OF EXPERIENCE. OURS IS BASED ON THE STRONG CONCEPT THAT PROFITABILITY CANNOT BE CONSIDERED WITHOUT SIMPLICITY OF USE, COUPLED WITH VERSATILITY IN FUNCTIONS.

No matter the job, the country or the corporate culture, we offer the best visibility, manoeuvrability and freedom on each construction site for optimal autonomy.





**LARGE DIGGING
AMPLITUDE**



STATIC LOAD



**UNIQUE
OVERFLOW
HEIGHT**



WATCH THE VIDEO



MWR 7.9.11

SET UP YOUR MWR

The new MWR comes standard equipped with a number of features, while at the same time remaining attentive to the specifications required by various types of customers: landscape and earthwork contractors, public works' professionals, municipal authorities, etc. So, from the color scheme to the choice of tires, heating/AC or cameras, not to mention the various attachments, buckets and hydraulic tools which can be used, there are many different ways to tailor your new MWR to your brand and business.



CUSTOM COLORS

You wish to get your MWR with your brand colors ?
Customize your Mecalac with your own RAL color codes.

Color examples



TIRES CHOICES

7MWR-9MWR

Simple Mitas 365/70 R18 EM (standard)
Large Alliance 500/45 R20
Twin BKT 8.25-20 (with spacer)

11MWR

Simple 18-19.5 (standard)
Large Alliance 600/40 R22.5
Twin BKT 9.00-20 (with spacer)



CAB - COMFORT AND SAFETY

Air conditioning (increases cab height) (standard)
Rotating beacon
LED rotating beacon
Travel alarm
Lynx shout type adaptative travel alarm
Overload buzzer (additional to screen indicator)
Additional front working light (standard)
Rear working light
Stereo USB Bluetooth radio
Heated pneumatic seat
Cabin sun visor
Rear cam (in addition to the side cam)
Switch command ISO / SAE

FRAME

4 steered wheels 30 km/h (7MWR)
2 steered wheels 35km/h (9MWR)
2 steered wheels 30km/h (11MWR)
4 steered wheels 20km/h (9MWR and 11MWR)
4 steered wheels 35km/h (9MWR)
4 steered wheels 30km/h (11MWR)
Steering direction inversion (4 steer wheels only)
Mudguards (4 steer wheels only)
Front blade and stabiliser
Rubber protective pads under stabilisers
Clamshell grab support
Additional counterweight

ENGINE

Particles filter (DPF)
Automatic temporised engine stop
Electric gas oil pump with automatic stop
Anti-theft device - electronic immobilizer with 6 keys

AUXILIARY LINES

Additional auxiliary line (if slewing power grab or other fuction)
Additional proportional auxiliairy line
Hammer return line

ANTIDROP SAFETY VALVES

Safety valves on boom, adjustable boom, dipperstick
Safety valves on boom, adjustable boom, dipperstick, bucket

QUICK COUPLING

CONNECT quick coupler - with hook
Device for the Direct Coupling of tools on dipperstick ("pin-on") with pins, hook, in-cab switch and hydraulic lines for quick couplers

LUBRICATION

Standard manual greasing: single point for turret and first boom (standard)
Centralized, manual lubrication for turret and equipment (except axles between connecting rod and quick coupling system)
Centralized, automatic lubrication for turret and equipment (except axles between connecting rod and quick coupling system)

OIL CHOICES

Hydraulic oil (VG 46) (standard)
Hydraulic oil Syn Panolin (HLP 46)
Hydraulic organic oil Panolin (HLP 46)
Hydraulic oil for cold weather (ISO 32)
Hydraulic oil for hot weather (ISO 68)
Hydraulic oil for very hot weather (ISO 100)



MWR 7.9.11

ACCESSORIES

MECALAC EXCLUSIVE



DIGGING BUCKETS

7MWR	WIDTH mm (ft in)	number of teeth	VOLUME l (yd³)	WEIGHT kg (lb)
DIGGING BUCKET with teeth or no teeth	350 (1'2")	3	100 (0.13)	121 (266)
	450 (1'6")	3	130 (0.17)	131 (288)
	600 (2')	4	185 (0.24)	150 (330)
	750 (2'5.5")	5	240 (0.31)	169 (372)
	900 (2'11")	5	300 (0.39)	185 (407)
9MWR	WIDTH mm (ft in)	number of teeth	VOLUME l (yd³)	WEIGHT kg (lb)
DIGGING BUCKET with teeth or no teeth	350 (1'2")	3	115 (0.15)	130 (286)
	450 (1'6")	3	150 (0.20)	140 (308)
	600 (2')	4	220 (0.29)	160 (352)
	750 (2'5.5")	5	285 (0.37)	180 (396)
	900 (2'11")	5	355 (0.46)	197 (434)
11MWR	WIDTH mm (ft in)	number of teeth	VOLUME l (yd³)	WEIGHT kg (lb)
DIGGING BUCKET with teeth or no teeth	350 (1'2")	3	150 (0.20)	204 (449)
	450 (1'6")	3	190 (0.25)	222 (489)
	600 (2')	3	275 (0.36)	255 (562)
	750 (2'5.5")	4	360 (0.47)	292 (643)
	900 (2'11")	4	450 (0.59)	328 (723)
	1200 (3'11")	5	630 (0.82)	393 (866)

NARROW BUCKET

TYPE	WIDTH mm (ft in)	number of teeth	VOLUME l (yd³)	WEIGHT kg (lb)
NARROW BUCKET	300 (1')	3	80 (0.10)	219 (482)

LOADER BUCKETS (SKID AND 4X1)

7MWR	WIDTH mm (ft in)	number of teeth	VOLUME l (yd³)	WEIGHT kg (lb)
SKID BUCKET no teeth	2200 (7'3")	-	540 (0.71)	378 (833)
9MWR	WIDTH mm (ft in)	number of teeth	VOLUME l (yd³)	WEIGHT kg (lb)
SKID BUCKET no teeth	2310 (7'7")	-	570 (0.75)	389 (857)
11MWR	WIDTH mm (ft in)	number of teeth	VOLUME l (yd³)	WEIGHT kg (lb)
SKID BUCKET no teeth	2500 (8'2")	-	820 (1.1)	475 (1,047)
SKID BUCKET 4x1 with or without teeth	2200 (7'3")	7	540 (0.71)	611 (1,374)
4X1 BUCKET CONNECTION SET, 4 FLEXIBLE JOINTS	-	-	-	5 (11)
BOLTED COUNTERBLADE FOR 4X1 BUCKET with no teeth 7 boreholes - center-to-center borehole distance 360 mm (1'2")	2300 (7'6.5")	-	-	65 (143.5)

PALLET FORK

TYPE	Specifications	WEIGHT kg (lb)
PALLET FORK	to be used with 4 safety valves	330 (728)

DITCHING BUCKET AND COUNTER-BLADE

7MWR - 9MWR	Specifications	WIDTH mm (ft in)	VOLUME l (yd³)	WEIGHT kg (lb)
DITCHING BUCKET 1 COUPLING	-	1500 (4'11")	262 (0.34)	260 (573)
BOLTED COUNTER BLADE	borehole center-to-center distance 160 (0'52")	1500 (4'11")	-	-
11MWR	Specifications	WIDTH mm (ft in)	VOLUME l (yd³)	WEIGHT kg (lb)
DITCHING BUCKET 1 COUPLING	-	1800 (5'11")	314 (0.41)	295 (650)
DITCHING BUCKET 3 COUPLINGS	-	1800 (5'11")	314 (0.41)	340 (750)
BOLTED COUNTER BLADE	borehole center-to-center distance 160 mm (0'52")	1800 (5'11")	-	47 (104)

ROTATING TRAPEZOIDAL BUCKET

11MWR	Dimensions mm (ft in)	WEIGHT kg (lb)
ROTATING TRAPEZOIDAL BUCKET	300 X 900 X H 700 (0'12" X 2'11" X 2'4")	190 (418)
ROTATING TRAPEZOIDAL BUCKET	400 X 900 X H 1200 (1'4" X 2'11" X 3'11")	315 (695)

HANDLING PLATE AND HAMMER PLATE

TYPE	Specifications	WEIGHT kg (lb)
HANDLING PLATE with hook	to be used with 3 safety valves	43 (94)
HAMMER plate no boreholes	-	80 (176)
HAMMER plate with boreholes	contact your dealer	80 (176)

HANDLING JIB

7MWR - 9MWR	Specifications	WEIGHT kg (lb)
HANDLING JIB	length 2000 mm (6'7"), lifting capacity 500 Kg (1,100 lb) to be used with 4 safety valves	80.5 (177)
11MWR	Specifications	WEIGHT kg (lb)
HANDLING JIB	length 4100 mm (13'5"), lifting capacity 500 Kg (1,100 lb) to be used with 4 safety valves	113 (249)

CLAMSHELL BUCKET SUPPORT

TYPE	Specifications	WEIGHT kg (lb)
SUPPORT PIECE FOR CLAMSHELL BUCKET - 7MWR, 9MWR, 11MWR	-	67 (147)

RIPPER TOOTH

TYPE	WEIGHT kg (lb)
RIPPER TOOTH	170 (374)

7.9.11MWR

TECHNICAL DATA

WEIGHT	7MWR	9MWR	11MWR
In running order, without bucket, with 75 kg (165 lb) operator, fuel tank full without optional equipment, standard tires			
- Rear blade	6925 kg (15,300 lb)	7900 kg (17,400 lb)	10000 kg (22,050 lb)
- Front stabilisers + blade	not available	+300 kg (+661 lb)	+450 kg (+992 lb)
- Large tires	+60 kg (+132 lb)	+60 kg (+132 lb)	+160 kg (+352 lb)
- Twin tires	+350 kg (+771 lb)	+350 kg (+771 lb)	+380 kg (+837 lb)

ENGINE	7MWR	9MWR	11MWR
Turbo charged engine with intercooler, EGR valve and catalytic converter (DOC), complying with regulation			
	Tier 4 Final Stage IIIB	Tier 4 Final Stage IIIB	Tier 4 Final Stage IIIB
Diesel 4 in-line cylinders	DEUTZ TCD 2.9 L4	DEUTZ TCD 2.9 L4	DEUTZ TCD 3.6 L4
Horsepower (DIN 70020)	55.4 kW (75hp - 74.3 imperial hp)	55.4 kW (75hp - 74.3 imperial hp)	55.4 kW (75hp - 74.3 imperial hp)
Engine speed	2300 rpm	2300 rpm	2200 rpm
Maximum torque	300 Nm at 1600 rpm (221 ft.lbf at 1600 rpm)	300 Nm at 1600 rpm (221 ft.lbf at 1600 rpm)	390 Nm at 1300 rpm (288 ft.lbf at 1300 rpm)
Cubic capacity	2900 cm ³ (177 in ³)	2900 cm ³ (177 in ³)	3600 cm ³ (220 in ³)
Cooling	water	water	water
Air filter, cyclonic, dry, cartridge	•	•	•
Fuel consumption (depending on operating conditions)	8 to 9 l/h	8 to 9 l/h	7 to 11 l/h
Fuel tank capacity	108 l	140 l	165 l

ELECTRICAL SYSTEM	7MWR	9MWR	11MWR
Voltage		12 V	
Batteries		100 Ah / 720 A	
Alternator		14 V (120 A)	
Starter		12 V 2.6 kW	

UNDERCARRIAGE	7MWR	9MWR	11MWR
Rigid	•	•	•
Outside turning radius			
- 4 steered wheels (optional)	3.52 m (11 ft 7 in)	3.56 m (11 ft 8 in)	3.86 m (12 ft 8 in)
- 2 steered wheels	6.08 m (19 ft 11 in)	6.10 m (20 ft)	6.41 m (21 ft)
Stabilisers controlled independently or in pairs	not available	•	•

TRANSMISSION	7MWR	9MWR	11MWR
Closed hydrostatic center with Senso Drive automotive type automatic regulation			
	•	•	•
Electronically controlled traveling direction reverser located under joystick	•	•	•
Hydraulic variable displacement pump and motor allow for a continuously variable transmission rate over the whole speed range of the machine			
	•	•	•
Continuously variable speed	0-30 km/h (i.e. 0-19 mph)	0-20 km/h (0-35 km/h in option) (0-12 mph (0-22 mph in option))	0-20 km/h (0-30 km/h in option) (0-12 mph (0-19 mph in option))
Max. traction force	3760 daN (8,450 lbf)	4820 daN (10,835 lbf)	4820 daN (10,835 lbf)
Gradeability	60%	65%	68%
Gearbox with automatic shifting	not available	option	option

7.9.11MWR

TECHNICAL DATA

AXLES AND WHEELS	
4-wheel drive	•
Rigid drive axle on the rear	steering as an option
Oscillating drive axle on the front to +/- 7° ; oscillation block involves 2 hydraulic cylinders	steering

BRAKES	
Double circuit central braking system	•
Oil-immersed multi-disk brakes on each axle	•

HYDRAULIC SYSTEM	7MWR	9MWR	11MWR
Hydraulic oil tank	56 l	61 l	77 l
Hydraulic circuit capacity	115 l	115 l	115 l

ATTACHMENT AND ROTATION CIRCUIT	7MWR	9MWR	11MWR
Variable displacement pump	45 cm ³ (2.7 in ³)	63 cm ³ (3.8 in ³)	75 cm ³ (4.6 in ³)
ACTIVE CONTROL power control 'Load Sensing - Flow Sharing' type LUDV main control valve block, proportionality of functions maintained regardless of the pressure level in individual elements	•	•	•
- Maximum flow rate	100 l/min	145 l/min	165 l/min
- Maximum working pressure	280 bar (4,060 psi)	280 bar (4,060 psi)	300 bar (4,350 psi)

TRANSMISSION CIRCUIT	7MWR	9MWR	11MWR
Pump	125 l/min	125 l/min	125 l/min
Max. pressure	440 bar (6,382 psi)	440 bar (6,382 psi)	440 bar (6,382 psi)

TURRET	7MWR	9MWR	11MWR
Full rotation 360°	•	•	•
Slewing by slow hydraulic motor with automatic braking assured by discs equipped with anti-bounce pressure relief valve	•	•	•
Driven by internal crown slewing wheel	•	•	•
Rotation speed	10 rpm	10 rpm	10 rpm
Rotation torque	1330 daNm (9,800 ft.lbf)	1690 daNm (12,400 ft.lbf)	2125 daNm (15,700 ft.lbf)

CAB	7MWR	9MWR	11MWR
Extremely comfortable panoramic cab		ROPS and FOPS	
Monocoque cab fastened to 4 spring posts	•	•	•
Front windshield partially or fully removable		under the cab roof	
Seat can be set and adjusted to operator height and weight	•	•	•
Water heating system compliant with ISO 10263	•	•	•
Independent settings for control lever support consoles	•	•	•
Controls assisted by ergonomic, proportional control levers	•	•	•
Dial display of fuel level and coolant temperature	•	•	•
Control panel including colour screen	•	•	•
Proportional hydraulic control of the attachment integrated on right-hand joystick	•	•	•
Front working light	•	•	•

ATTACHMENT	7MWR	9MWR	11MWR
Mecalac variable range kinematics consisting of 4 parts: boom, adjustable boom, offset boom and dipperstick	•	•	•
33° right and left offset by hydraulic cylinder. System enabling all penetration force to be conserved regardless of the angular position of the offset boom	•	•	•
Left offset	1382 mm (54 in)	1554 mm (61 in)	1775 mm (70 in)
Right offset	1824 mm (72 in)	1600 mm (63 in)	2034 mm (80 in)
Boom cylinder with endof travel shock absorber	•	•	•
CONNECT quick coupler			
- Take up with automatic mechanical locking	•	•	•
- Detection of incorrect locking			
- Hydraulically-controlled unlocking			

OPERATING MODES

WORKING MODE
Enables the machine to be operated like an excavator:

- Turret rotation and dipperstick control with the left control lever
- Bucket and intermediate boom or boom control with the right control lever
- Travelling control using foot pedals

DRIVING MODE

- Deactivation of the manual engine speed control. The engine speed varies depending on how far the travel pedal is depressed
- Turning on road headlights
- Turning on rotating beacon
- Locking of machine hydraulic functions (attachment, slewing, outriggers)
- Deactivation of oscillation lock (only if oscillation lock selector is on AUTO) and is not activated via the right joystick
- Deactivation of the travel alarm
- Deactivation of the overload alarm
- Display of speed in km/h
- Deactivation of idle function via keypad and joystick
- Speed controller
- Screen display in road mode

PARKING MODE

- Engage parking brake
- Turn the transmission into Neutral
- Deactivation of the accelerator pedal
- Set engine rpm into idle
- Lock hydraulic and electrical controls
- Screen display in economy mode
- Lock oscillating axle
- Turn on road headlights

NOTE
METRIC MEASUREMENTS ARE THE CRITICAL VALUES
DIMENSIONS ARE TAKEN FROM T152021

- 1 Litre = 0.26417 US Liquid Gallons
- 1 Litre = 0.21997 Imperial Liquid Gallons

7.9.11MWR

TECHNICAL DATA

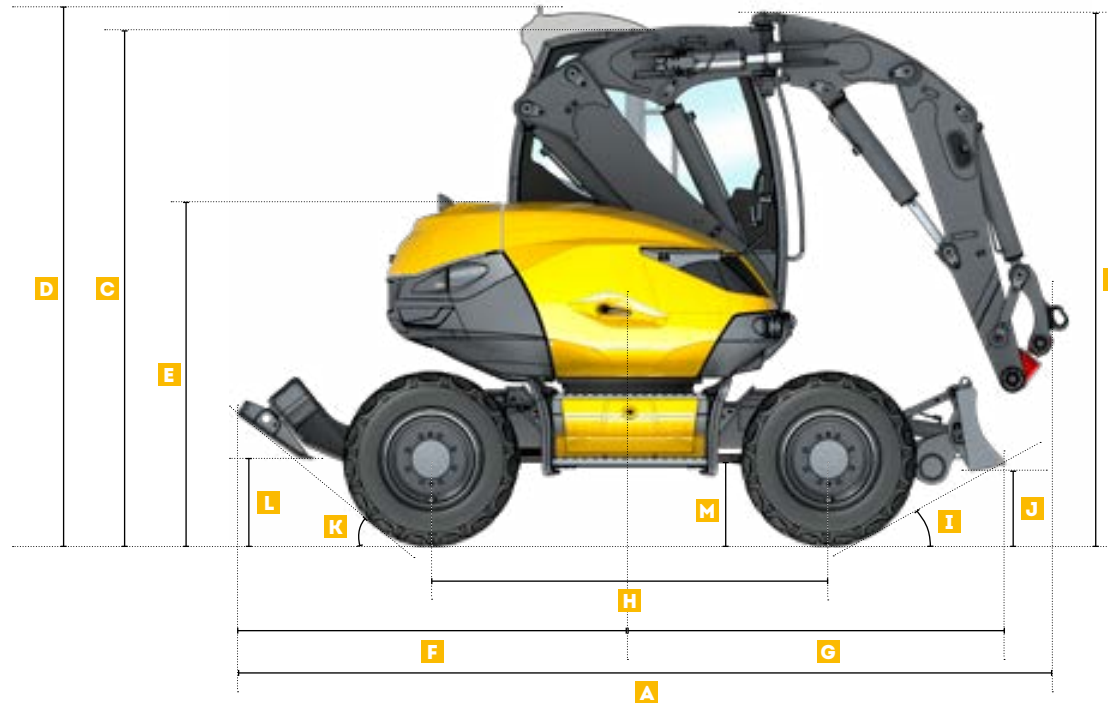

MACHINE DIMENSIONS	7MWR	9MWR	11MWR
A Overall length with attachment (without stabilisers for the 7MWR)	3730 mm (12'3")	4418 mm (14'6")	4836 mm (15'1")
B Overall height of structures	2816 mm (9'3")	2945 mm (9'8")	3256 mm (10'8")
C Cab height (without attachment)	2816 mm (9'3")	2829 mm (9'3")	2944 mm (9'8")
D Cab height (without attachment, with AC option)	2944 mm (9'8")	2957 mm (9'8")	3072 mm (10'1")
E Cover height	1865 mm (6'1")	1886 mm (6'2")	2030 mm (6'8")
F Overhang of lower frame on stabilisers side (without stabilisers for the 7MWR)	1550 mm (5'1")	2159 mm (7'1")	2275 mm (7'6")
G Overhang of lower frame on blade side	2030 mm (6'8")	2076 mm (6'1")	2230 mm (7'4")
H Wheelbase	2100 mm (6'11")	2200 mm (7'3")	2300 mm (7'7")
I Blade crossing angle	32°	28°	32°
J Height with blade raised	429 mm (1'5")	429 mm (1'5")	545 mm (1'9")
K Stabilisers crossing angle	-	39°	36°
L Height with stabilisers raised	-	430 mm (1'5")	413 mm (1'4")
M Ground clearance at axle	430 mm (1'5")	430 mm (1'5")	460 mm (1'6")

7.9.11MWR

TECHNICAL DATA

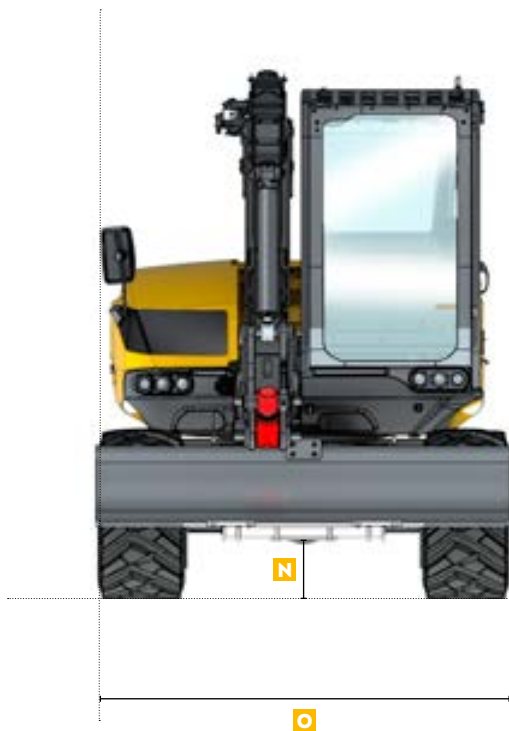

MACHINE DIMENSIONS	7MWR	9MWR	11MWR
N Ground clearance at gearbox	310 mm (1')	310 mm (1')	350 mm (1'2")
O Width of blade	2180 mm (7'2")	2310 mm (7'7")	2500 mm (8'2")

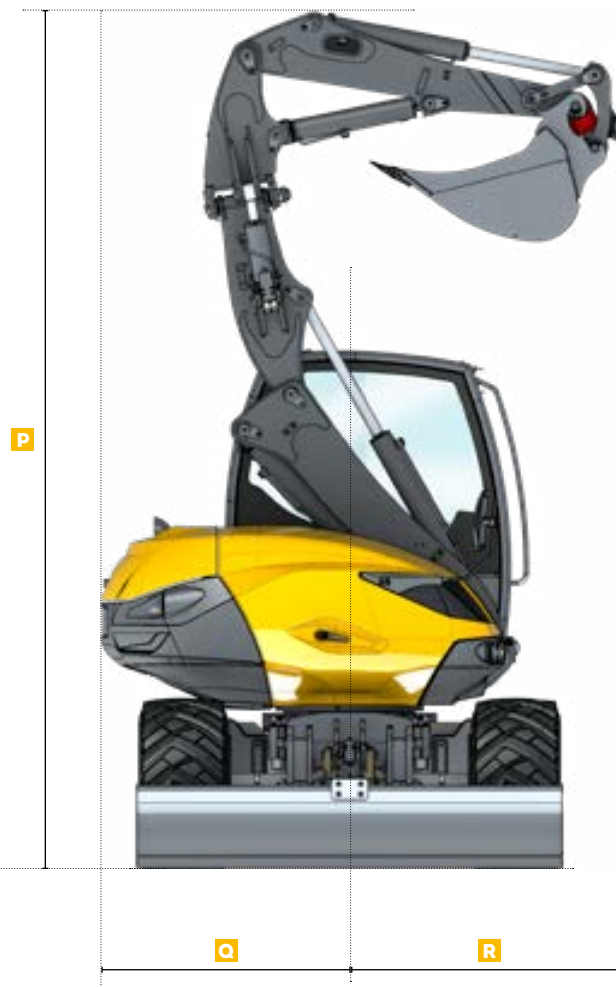

MACHINE DIMENSIONS	7MWR	9MWR	11MWR
P Height in folded position	4410 mm (14'6")	4630 mm (15'2")	5090 mm (16'8")
Q Tail swing radius	1296 mm (4'3")	1350 mm (4'5")	1445 mm (4'9")
R Front radius	1492 mm (4'11")	1516 mm (4'12")	1851 mm (6'1")



7.9.11MWR DIGGING



7MWR

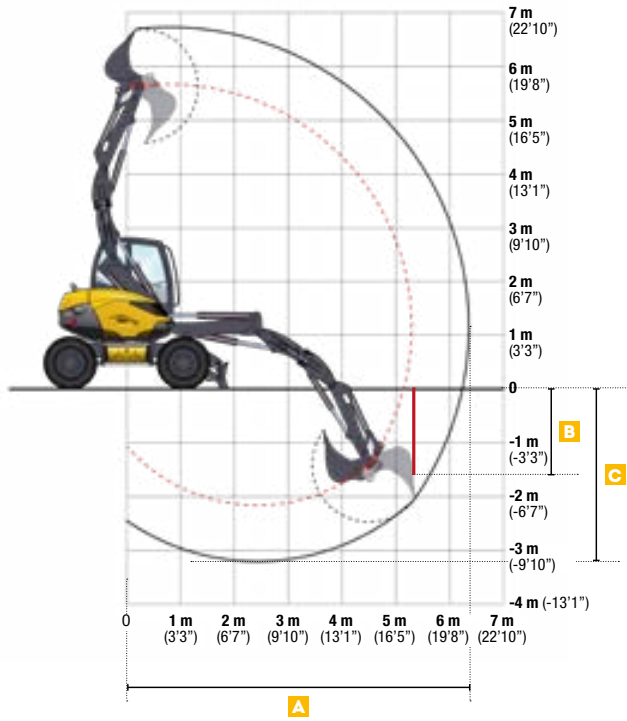

9MWR

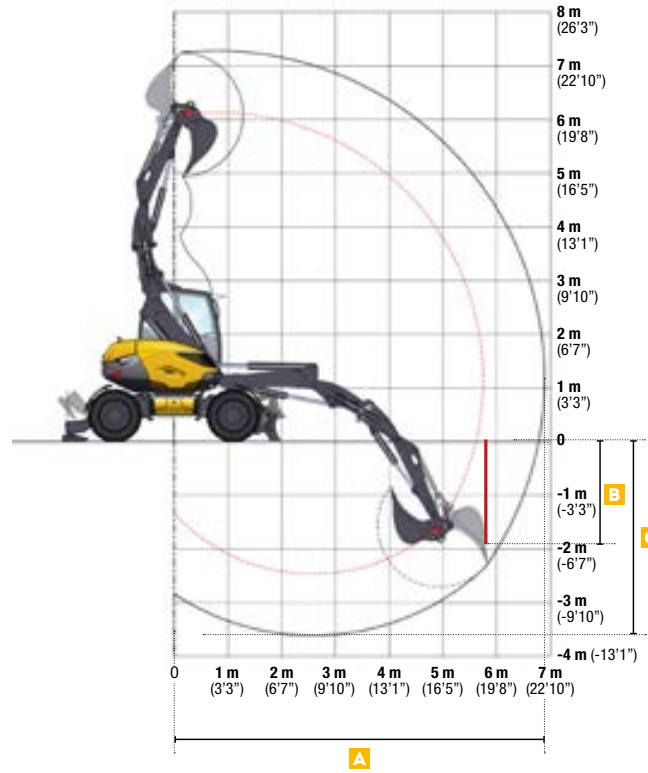

11MWR

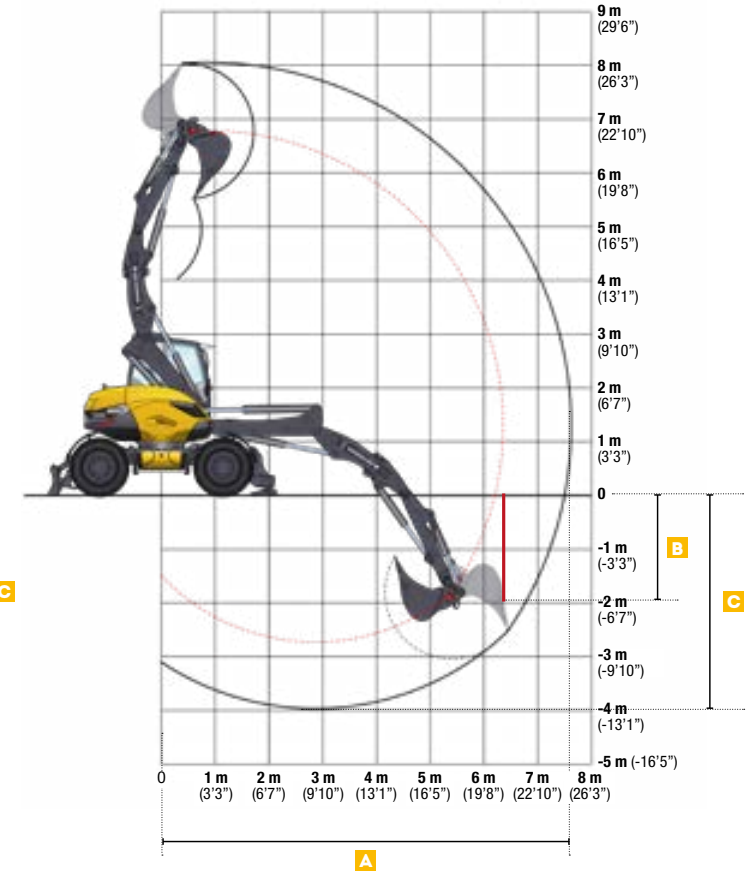

MACHINE DIMENSIONS

	7MWR	9MWR	11MWR
A Maximum reach	6220 mm (20'5")	6700 mm (22')	7500 mm (24'7")
B Vertical digging depth maximum with standard bucket	1657 mm (5'5")	1928 mm (6'4")	1949 mm (6'5")
C Maximum digging depth	3030 mm (9'11")	3500 mm (11'6")	3800 mm (12'6")

DIGGING PERFORMANCE

	7MWR	9MWR	11MWR
Break-out force (max.)	4300 daN (9,666 lbf)	5000 daN (11,240 lbf)	6000 daN (13,500 lbf)
Penetration/Tear-out force (max.)	2500 daN (5,620 lbf)	2800 daN (6,300 lbf)	3400 daN (7,650 lbf)



7MWR - HANDLING

LIFTING CAPACITY WITH PALLET FORKS

All the weights are given in kg (lb). The calculations are carried out for the entire range of the Mecalac quick coupler.

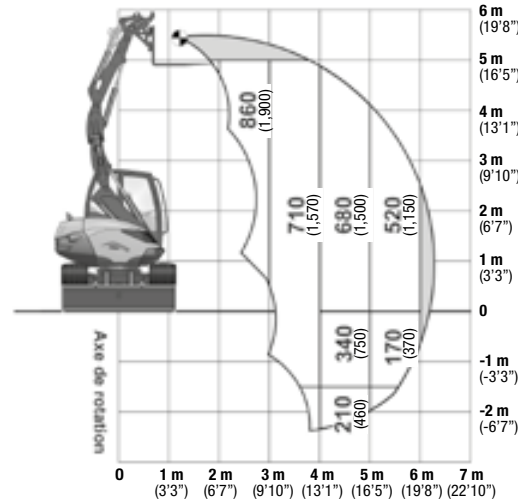
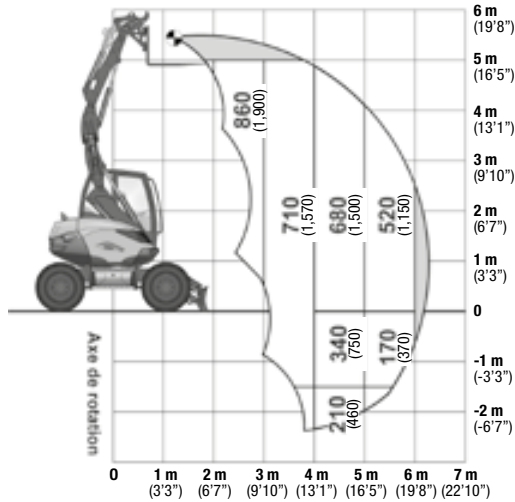

WORKING CONDITIONS

- On wheels with blade on ground
- On horizontal, compact ground
- Equipment used without offset
- Oscillation axle blocked
- Equipped with pallet fork
- Machine equipped with 4 safety valves

ACCORDING TO ISO 10567

- Maximal 75% of the tipping load or 87% of the hydraulic capacity
- Maximum values determined for the most unfavorable position of boom and cylinders

LIFTING CAPACITY WITH LOADING HOOK - BLADE ON GROUND

All the weights are given in kg (lb). The calculations are carried out for the entire range of the Mecalac quick coupler.

	2M (6'7")		3M (9'10")		4M (13'1")		5M (16'5")	
5M (16'5")	3000 (6,600)	3000 (6,600)	2560 (5,640)	2560 (5,640)	-	-	-	-
3M (9'10")	3000 (6,600)	3000 (6,600)	3000 (6,600)	3000 (6,600)	2130 (4,700)	2130 (4,700)	1610 (3,550)	1520 (3,350)
15M (4'11")	3000 (6,600)	3000 (6,600)	3000 (6,600)	3000 (6,600)	2270 (5,000)	2200 (4,850)	1720 (3,800)	1480 (3,260)
0M	3000 (6,600)	3000 (6,600)	3000 (6,600)	3000 (6,600)	3000 (6,600)	2060 (4,540)	1710 (3,770)	1300 (2,870)
-1M (-3'3")	3000 (6,600)	3000 (6,600)	3000 (6,600)	3000 (6,600)	2260 (4,980)	1980 (4,370)	1120 (2,470)	1120 (2,470)
-2M (-6'7")	3000 (6,600)	3000 (6,600)	2020 (4,450)	2020 (4,450)	1190 (2,620)	1190 (2,620)	-	-



Working in longitudinal position on blade side



Working in transverse position

LIFTING CAPACITY WITH LOADING HOOK - BLADE RAISED

All the weights are given in kg (lb). The calculations are carried out for the entire range of the Mecalac quick coupler.

	2M (6'7")		3M (9'10")		4M (13'1")		5M (16'5")	
5M (16'5")	3000 (6,600)	3000 (6,600)	2560 (5,640)	2560 (5,640)	-	-	-	-
3M (9'10")	3000 (6,600)	3000 (6,600)	3000 (6,600)	3000 (6,600)	2130 (4,700)	1700 (3,750)	1550 (3,420)	1150 (2,540)
15M (4'11")	3000 (6,600)	3000 (6,600)	3000 (6,600)	3000 (6,600)	2250 (4,960)	1460* (3,220*)	1530 (3,370)	980* (2,160)
0M	3000 (6,600)	3000 (6,600)	3000 (6,600)	2560 (5,640)	2160 (4,760)	1450 (3,200)	1460 (3,220)	940* (2,070)
-1M (-3'3")	3000 (6,600)	3000 (6,600)	3000 (6,600)	2300 (5,070)	2050 (4,520)	1480 (3,260)	1120 (2,470)	1050 (2,310)
-2M (-6'7")	3000 (6,600)	3000 (6,600)	2020* (4,450*)	2020 (4,450)	1190 (2,620)	1190 (2,620)	-	-



Working in longitudinal position on blade side



Working in transverse position

WORKING CONDITIONS

- On wheels with stabilisers on ground or raised
- On horizontal, compact ground
- Equipment used without offset
- Front and rear frame aligned
- Without tools (bucket, shovel...) with handling plate and loading hook of 3 T
- Maximal 75% of the tipping load or 87% of the hydraulic capacity
- Maximum values determined for optimal position of boom and cylinders

The lifting capabilities shown with an asterisk (*) are limited by the tipping load that can be lifted. Other values are limited by the hydraulic capabilities or capabilities of the loading hook. The weight of the chain sling, bucket and other auxiliary lifting devices must be deducted from the nominal load to determine the load which can be lifted.



9MWR - HANDLING

LIFTING CAPACITY WITH PALLET FORKS

All the weights are given in kg (lb). The calculations are carried out for the entire range of the Mecalac quick coupler.

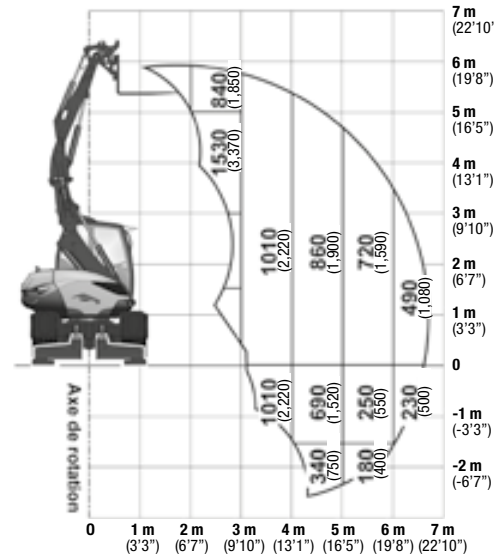
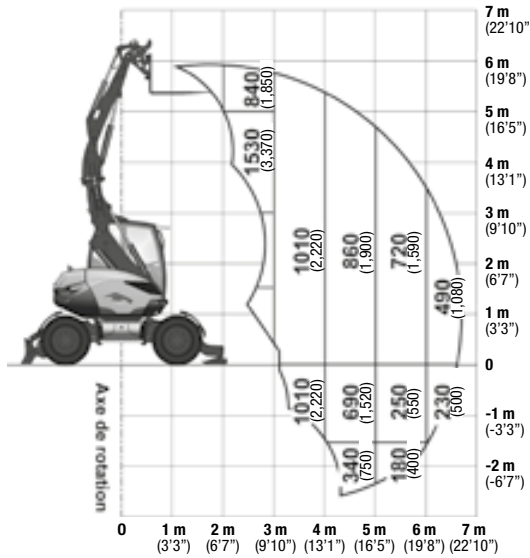

WORKING CONDITIONS

- On wheels with blade on ground
- On horizontal, compact ground
- Equipment used without offset
- Oscillation axle blocked
- Equipped with pallet fork
- Machine equipped with 4 safety valves

ACCORDING TO ISO 10567

- Maximal 75% of the tipping load or 87% of the hydraulic capacity
- Maximum values determined for the most unfavorable position of boom and cylinders

LIFTING CAPACITY WITH LOADING HOOK - STABILISERS AND BLADE ON GROUND

All the weights are given in kg (lb). The calculations are carried out for the entire range of the Mecalac quick coupler.

	2M (6'7")		3M (9'10")		4M (13'1")		5M (16'5")	
5M (16'5")	3000 (6,600)	3000 (6,600)	3000 (6,600)	3000 (6,600)	2470 (5,450)	2470 (5,450)	-	-
3M (9'10")	3000 (6,600)	3000 (6,600)	3000 (6,600)	3000 (6,600)	2560 (5,640)	2560 (5,640)	2030 (4,480)	1810 (3,990)
15M (4'11")	3000 (6,600)	3000 (6,600)	3000 (6,600)	3000 (6,600)	3000 (6,600)	3000 (6,600)	2460 (5,420)	1710 (3,770)
0M	3000 (6,600)	3000 (6,600)	3000 (6,600)	3000 (6,600)	3000 (6,600)	2340 (5,160)	2270 (5,000)	1680 (3,700)
-1M (-3'3")	3000 (6,600)	3000 (6,600)	3000 (6,600)	3000 (6,600)	3000 (6,600)	2280 (5,030)	1780 (3,920)	1600 (3,530)
-2M (-6.7 ft)	3000 (6,600)	3000 (6,600)	3000 (6,600)	3000 (6,600)	1910 (4,210)	1910 (4,210)	900 (1,980)	900 (1,980)



Working in longitudinal position on blade side



Working in transverse position

LIFTING CAPACITY WITH LOADING HOOK - STABILISERS AND BLADE RAISED

All the weights are given in kg (lb). The calculations are carried out for the entire range of the Mecalac quick coupler.

	2M (6'7")		3M (9'10")		4M (13'1")		5M (16'5")	
5M (16'5")	3000 (6,600)	3000 (6,600)	3000 (6,600)	3000 (6,600)	2470 (5,450)	1940 (4,280)	-	-
3M (9'10")	3000 (6,600)	3000 (6,600)	3000 (6,600)	3000 (6,600)	2560 (5,640)	2120 (4,670)	1900 (4,190)	1250* (2,760*)
15M (4'11")	3000 (6,600)	3000 (6,600)	3000 (6,600)	3000 (6,600)	3000 (6,600)	1830* (4,030*)	1800 (3,970)	1210* (2,670)
0M	3000 (6,600)	3000 (6,600)	3000 (6,600)	3000 (6,600)	3000 (6,600)	1690* (3,730*)	1730 (3,810)	1130* (2,490*)
-1M (-3'3")	3000 (6,600)	3000 (6,600)	3000 (6,600)	3000 (6,600)	2370 (5,490)	1700 (3,750)	1710 (3,770)	1250 (2,760)
-2M (-6.7 ft)	3000 (6,600)	3000 (6,600)	3000 (6,600)	3000 (6,600)	1910 (4,210)	1700 (3,750)	1400 (3,090)	900 (1,980)



Working in longitudinal position on blade side



Working in transverse position

WORKING CONDITIONS

- On wheels with stabilisers on ground or raised
- On horizontal, compact ground
- Equipment used without offset
- Front and rear frame aligned
- Without tools (bucket, shovel...) with handling plate and loading hook of 3 T
- Maximal 75% of the tipping load or 87% of the hydraulic capacity
- Maximum values determined for optimal position of boom and cylinders

The lifting capabilities shown with an asterisk (*) are limited by the tipping load that can be lifted. Other values are limited by the hydraulic capabilities. The weight of the chain sling, bucket and other auxiliary lifting devices must be deducted from the nominal load to determine the load which can be lifted.



11MWR - HANDLING

LIFTING CAPACITY WITH PALLET FORKS

All the weights are given in kg (lb). The calculations are carried out for the entire range of the Mecalac quick coupler.

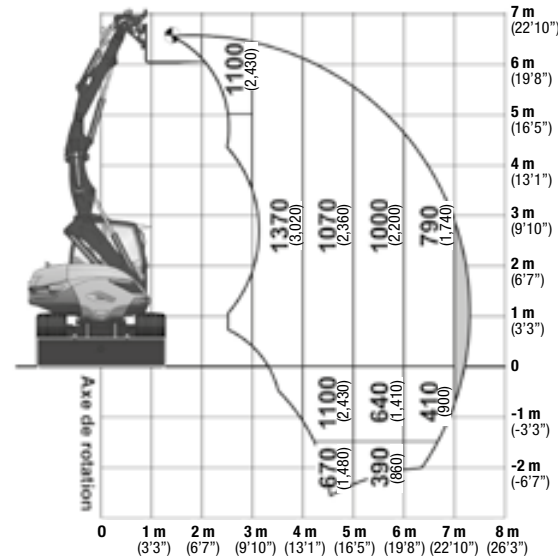
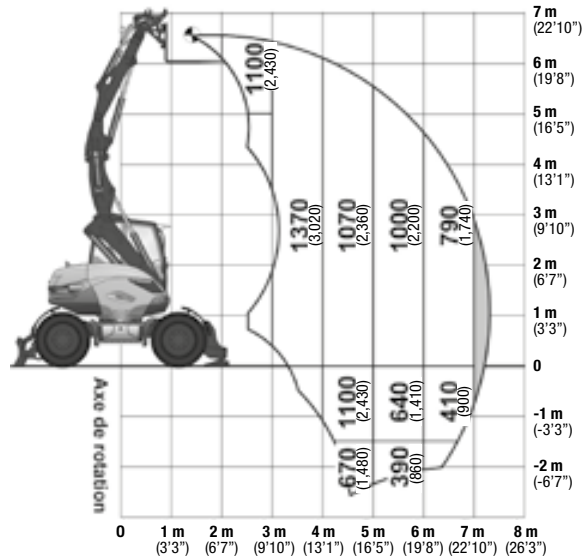

WORKING CONDITIONS

- On wheels with blade on ground
- On horizontal, compact ground
- Equipment used without offset
- Oscillation axle blocked
- Equipped with pallet fork
- Machine equipped with 4 safety valves

ACCORDING TO ISO 10567

- Maximal 75% of the tipping load or 87% of the hydraulic capacity
- Maximum values determined for the most unfavorable position of boom and cylinders

LIFTING CAPACITY WITH LOADING HOOK – STABILISERS AND BLADE ON GROUND

All the weights are given in kg (lb). The calculations are carried out for the entire range of the Mecalac quick coupler.

2M (6'7") 3M (9'10") 4M (13'1") 5M (16'5") 6M (19'8")



	2M (6'7")		3M (9'10")		4M (13'1")		5M (16'5")		6M (19'8")	
5M (16'5")	4000 (8,820)	4000 (8,820)	4000 (8,820)	4000 (8,820)	3400 (7,500)	3400 (7,500)	2740 (6,040)	2740 (6,040)	-	-
3M (9'10")	-	-	4000 (8,820)	4000 (8,820)	4000 (8,820)	4000 (8,820)	3080 (6,790)	3080 (6,790)	2360 (5,200)	2280 (5,030)
15M (4'11")	-	-	4000 (8,820)	4000 (8,820)	4000 (8,820)	4000 (8,820)	4000 (8,820)	2910 (6,420)	2820 (6,220)	2170 (4,780)
0M	4000 (8,820)	4000 (8,820)	4000 (8,820)	4000 (8,820)	4000 (8,820)	4000 (8,820)	4000 (8,820)	2590 (5,710)	3100 (6,830)	1830* (4,030*)
-1M (-3'3")	4000 (8,820)	4000 (8,820)	4000 (8,820)	4000 (8,820)	4000 (8,820)	4000 (8,820)	4000 (8,820)	2450* (5,400*)	2640 (5,820)	1790* (3,950*)
-2M (-6.7 ft)	4000 (8,820)	4000 (8,820)	4000 (8,820)	4000 (8,820)	4000 (8,820)	4000 (8,820)	3140 (6,920)	2690 (5,930)	-	-

Working in longitudinal position on blade side

Working in transverse position

LIFTING CAPACITY WITH LOADING HOOK – STABILISERS AND BLADE RAISED

All the weights are given in kg (lb). The calculations are carried out for the entire range of the Mecalac quick coupler.

2M (6'7") 3M (9'10") 4M (13'1") 5M (16'5") 6M (19'8")



	2M (6'7")		3M (9'10")		4M (13'1")		5M (16'5")		6M (19'8")	
5M (16'5")	4000 (8,820)	4000 (8,820)	4000 (8,820)	4000 (8,820)	3400 (7,500)	2900 (6,390)	2410 (5,310)	1660* (3,660)	-	-
3M (9'10")	-	-	4000 (8,820)	4000 (8,820)	4000 (8,820)	2830 (6,240)	2500 (5,510)	1690* (3,730*)	1520* (3,350*)	1160* (2,560*)
15M (4'11")	-	-	4000 (8,820)	4000 (8,820)	4000 (8,820)	2790 (6,150)	2090* (4,600)	1610* (3,550*)	1470* (3,240*)	1110* (2,450*)
0M	4000 (8,820)	4000 (8,820)	4000 (8,820)	4000 (8,820)	2990 (6,590)	2240* (4,940*)	2100 (4,630)	1480* (3,260*)	1600 (3,530)	1040* (2,290*)
-1M (-3'3")	4000 (8,820)	4000 (8,820)	4000 (8,820)	4000 (8,820)	3040 (6,700)	2120 (4,670)	2150 (4,740)	1490 (3,280)	1350* (2,980*)	1110 (2,450)
-2M (-6.7 ft)	4000 (8,820)	4000 (8,820)	4000 (8,820)	4000 (8,820)	2590* (5,710*)	2200 (4,850)	1790* (3,950*)	1350 (2,980)	-	-

Working in longitudinal position on blade side

Working in transverse position

WORKING CONDITIONS

- On wheels with stabilisers on ground or raised
- On horizontal, compact ground
- Equipment used without offset
- Front and rear frame aligned
- Without tools (bucket, shovel...) with handling plate and loading hook of 4 T
- Maximal 75% of the tipping load or 87% of the hydraulic capacity
- Maximum values determined for optimal position of boom and cylinders

The lifting capabilities shown with an asterisk (*) are limited by the tipping load that can be lifted. Other values are limited by the hydraulic capabilities. The weight of the chain sling, bucket and other auxiliary lifting devices must be deducted from the nominal load to determine the load which can be lifted.



7.9.11MWR HYDRAULIC ATTACHMENTS

NOTE
 METRIC MEASUREMENTS ARE THE CRITICAL VALUES
 DIMENSIONS ARE TAKEN FROM T152021
 • 1 Litre = 0.26417 US Liquid Gallons
 • 1 Litre = 0.21997 Imperial Liquid Gallons

7MWR

FLOW RATE / PRESSURE AUXILIARY 1 (PROPORTIONAL)

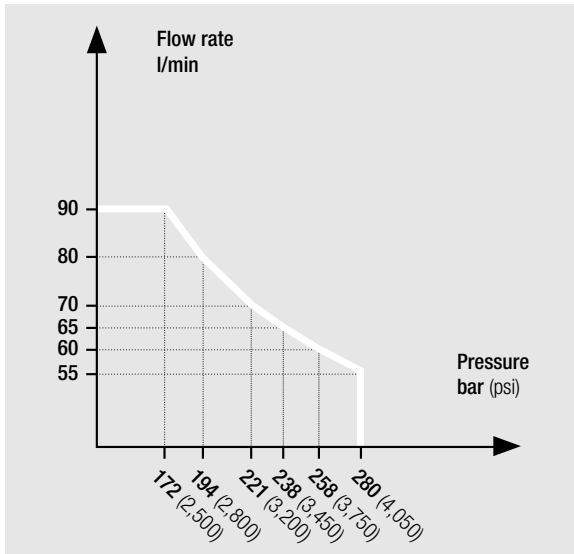

AUXILIARY LINE 2	DATA
Offset cylinder diverted (clamshell rotation)	
Flow rate maximum	30 l/min
Pressure	280 bar (4,050 psi)
Controls	Proportional as option

AUXILIARY LINE 3	DATA
Bucket cylinder diverted (clamshell function)	
Flow rate maximum	80 l/min
Pressure maximum	280 bar (4,050 psi)

9MWR

FLOW RATE / PRESSURE AUXILIARY 1 (PROPORTIONAL)

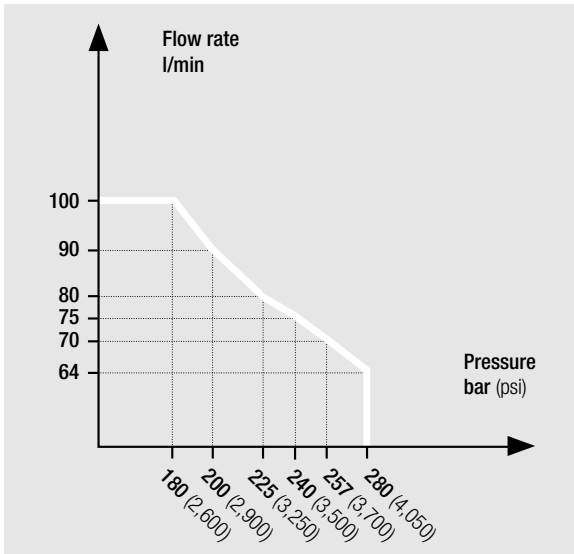

AUXILIARY LINE 2	DATA
Offset cylinder diverted (clamshell rotation)	
Flow rate maximum	30 l/min
Pressure	280 bar (4,050 psi)
Controls	Proportional as option

AUXILIARY LINE 3	DATA
Bucket cylinder diverted (clamshell function)	
Flow rate maximum	80 l/min
Pressure maximum	280 bar (4,050 psi)

11MWR

FLOW RATE / PRESSURE AUXILIARY 1 (PROPORTIONAL)

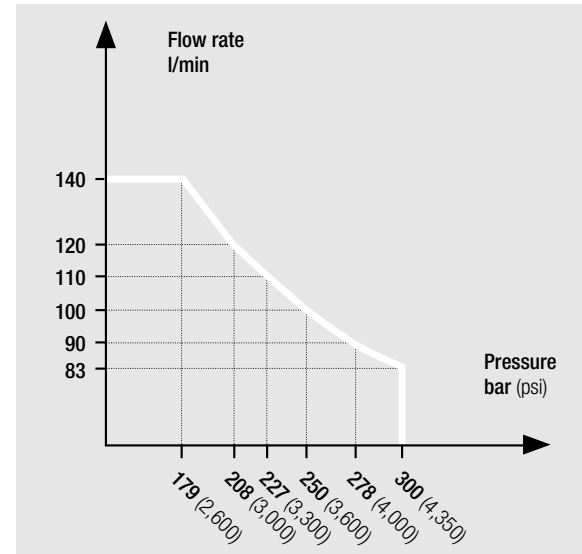

AUXILIARY LINE 2	DATA
Offset cylinder diverted (clamshell rotation)	
Flow rate maximum	30 l/min
Pressure	300 bar (4,350 psi)
Controls	Proportional as option

AUXILIARY LINE 3	DATA
Bucket cylinder diverted (clamshell function)	
Flow rate maximum	120 l/min
Pressure maximum	300 bar (4,350 psi)

MECALAC FRANCE S.A.S.
2, avenue du Pré de Challes
Parc des Glaisins – CS 40230
Annecy-le-Vieux
FR - 74942 Annecy Cedex
Tel: +33 (0) 4 50 64 01 63

WWW.MECALAC.COM

